

CONTENTS

- 1. GENERAL DESCRIPTION**
 - General Spec
- 2. IN/OUT CHARACTERISTIC**
 - Input characteristics
 - Output Characteristics
- 3. ENVIRONMENTAL and RELIABILITY**
 - Operating Conditions
 - Storage Conditions
 - Reliability
- 4. ELECTRICAL CHARACTERISTICS**
 - Power Management
- 5. SUPPORTED TIMING**
 - Output Mode
- 6. OSD CONTROL**
 - Main OSD
 - Sub OSD
- 7. OSD KEY INFORMATION**
- 8. REMOTE CONTROL**
 - Key Map
- 9. CODEC SUPPORT**
- 10. CONNECTOR INFORMATION**
- 11. BOARD DIMENSION**

1. General Description

-DW703MF Board performs real-time digital video decoding and playback of MPEG1,MPEG2, MPEG4, H.264/MPEG4 AVC and Real Video® on both SD and HD sources.

The embedded high performance audio digital signal processor supports Dolby Digital, MPEG/II Layer1/2, DTS and processing.

-.This controller board is designed for a DID Display and other Multi Media application.

1-1. General Spec

- Max Resolution Up to 1920*1080P
- TMD5 Input up to 165MHz
- 5Wx2 Audio Output
- Dual/single LVDS Interface
- Support Panel DC 3.3V,DC 5V and 12V
- FHD Video Display (up to 1080P)
- USB2.0 Host
- USB , HDMI , RGB INPUT
- IR Support
- Two HDMI Input ports
- HDMI 1.3/1.4 Compliant
- HDCP 1.2 Compliant

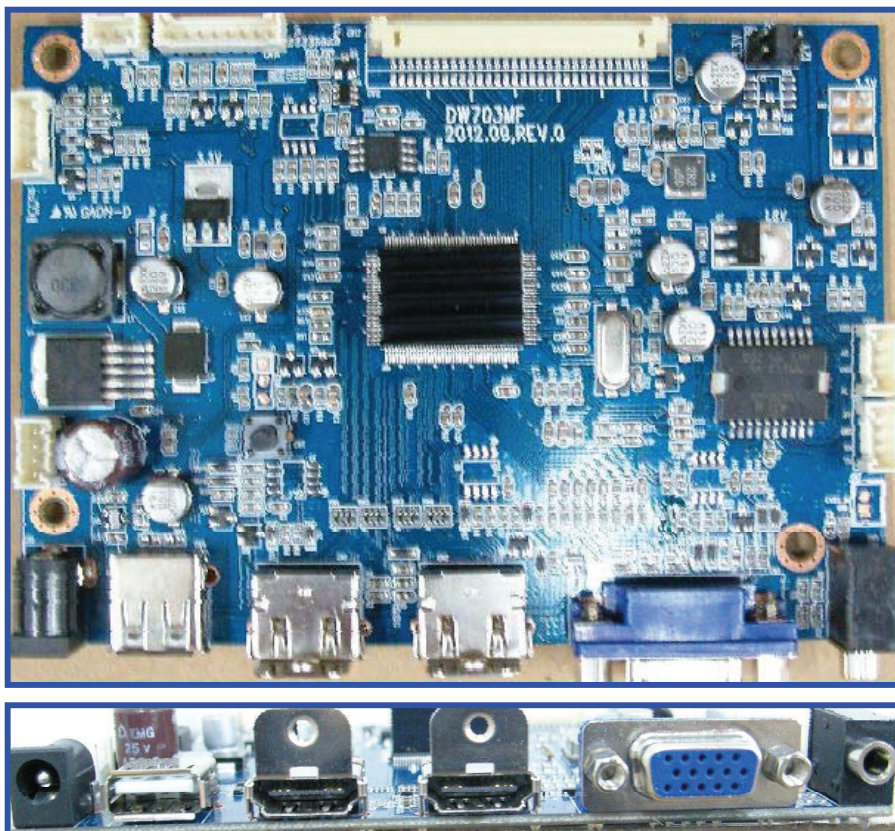

DC IN USB 2*HDMI RGB AUDIO IN

2. IN/OUT Characteristic

2-1. Input characteristic

Description	Signal	Unit	Min	Typical	Max	Remark
DC Power	Input	VDC	11.5	12	13.5	
	Consumption	Watt		8		
Input Frequency	H Frequency					
	V Frequency	Hz	TBD	60	TBD	
HDMI Output	TMDS	mVp-p	450	500	900	

3. Environmental and Reliability

3-1. Operating Conditions

Temperature	0 °C ~ 50 °C
Humidity	20% ~ 90%, (Ta≤40°C), non-condensing

3-2. Storage Conditions

Temperature	-20 °C ~ 65 °C
Humidity	5% ~ 90%, (Ta≤40°C), non-condensing

3- 3. Reliability

MTBF : more than 50,000 hours at 90% confidence level

4. Electrical Characteristics

4-1. Power Management

Status	Mode	Consumption	LED Color
Power On	Normal Mode (Display mode)	TBD	GREEN / BLUE
	Power Saving Mode (standby, suspend, off)	Less then 1W	RED
Power Off	POWER OFF	Less then 1W	OFF

5. Support Timing

5-1. VESA Preset Timing

MODE	Resolution	Support Model	H Frequency (Khz)	Pixel Clock (Mhz)	REMARK
VGA	640x480@60Hz	DW703MF	31.5	25.1	
	640x480@72Hz		37.9	31,5	
	640x480@75Hz		37.5	31.5	
SVGA	800x600@60Hz		37.9	40.0	10.4" Max
XGA	1024x768@60Hz		48.4	65.0	15"(16:10)Max
SXGA	1280x1024@60Hz		64	108.0	17"/19" Max
HD	1360x768@60Hz		47.7	86.5	HD
	1366x768@60Hz		47.7	86.5	
SXGA+	1440x900@60Hz		55.5	88.75	W19"(16:9) Max
	1600x900@60Hz		55.9	118.0	
WSXGA+	1680x1050@60Hz		64.7	119.0	22"(16:10) Max
UXGA	1600x1200@60Hz		75	162.0	
FHD	1920x1080@60Hz		67.5	148.5	FHD PANEL
WUXGA	1920x1200@60Hz		74	154.0	24"(16:10) Max

5-2. Video Preset Timing

NO	MODE	V-Freq	ETC
1	480i	30	AV input Mode
2	480p	60	
3	576i	25	
4	576p	50	
5	720p	50	
6	720p	60	
7	1080i	25	
8	1080i	30	
9	1080p	50	
10	1080p	60	

6. OSD Control

IMAGE 1 : PICTURE

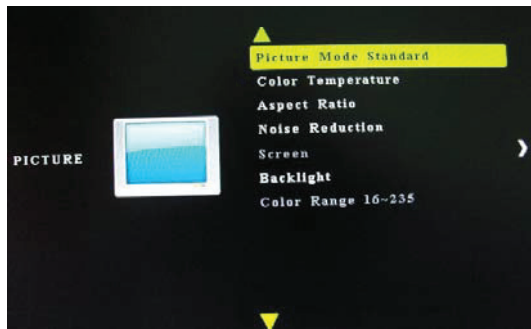

IMAGE 2 : SOUND

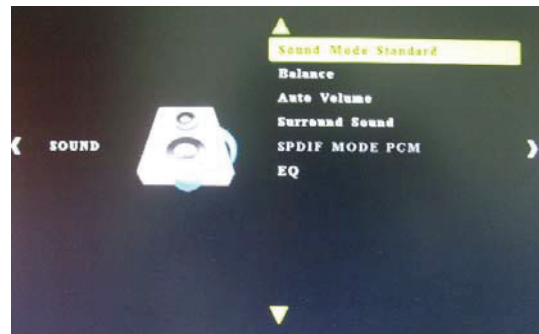

IMAGE 3 : TIME

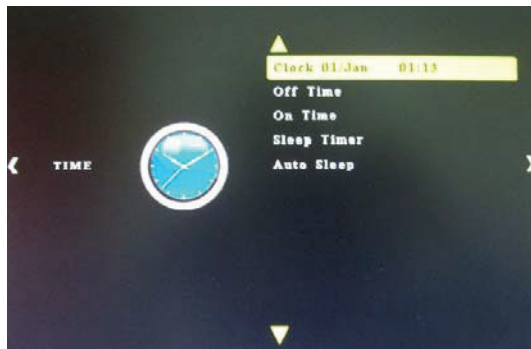

IMAGE 4 : OPTION

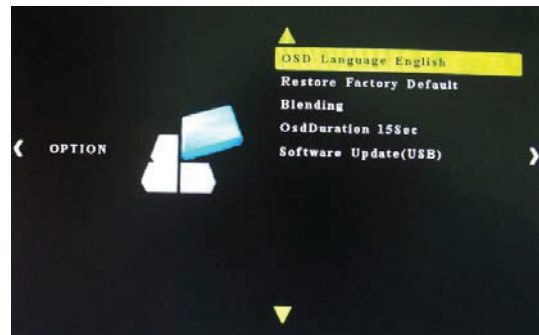
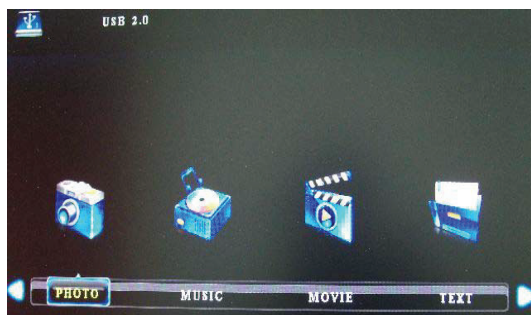

IMAGE 5 : USB Mode



6-1. Main OSD Item

IMAGE	Description	Remark
IMAGE 1	Picture	PICTURE / COLOR
IMAGE 2	Sound	SOUND
IMAGE3	Time	TIMER
IMAGE4	Option	UPDATE , LANGUAGE , OSD
IMAGE5	Multi Media	PHOTO , MUSIC , MOVIE , TEXT

6-2. OSD Structure (RGB / HDMI)

Main Item	Sub Item1	Sub Item2	Action	Remark
PICTURE	Mode		Adjust the value of picture mode	
	Color Temp		Adjust the value of color mode	
	Aspect Ratio		Adjust the value of aspect ratio	
	Screen		Adjust H/V position of image	RGB Only
	Backlight		Adjust the value of Backlight	
	Color Range		Adjust the value of color Range	HDMI Only
SOUND	Sound mode		Adjust the value of Sound mode	
	Balance		Adjust the value of speaker balance	
	Auto Volume		Auto adjust of the audio volume	
	Surround		Adjust the value of audio surround	
	EQ		Adjust the value of audio equalizers	
TIME	Clock		Adjust the value of clock	
	Off Time		Adjust the value of off time	
	On Time		Adjust the value of on time	
	Sleep Timer		Adjust the value of sleep time	
	Auto Sleep		Adjust the value of auto sleep time	
OPTION	Language		Select Language	
	Factory Default		Adjust the value of Recall	
	Blending		Adjust the value of OSD blending	
	OSD Duration		Adjust the value of OSD duration	
	S/W Update		Adjust the value of Software update(USB)	

6-3. INPUT SOURCE

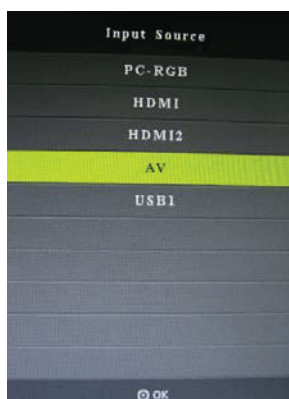

INPUT SOURCE

- PC – RGB
- HDMI1
- HDMI2
- AV(Optional)
- USB1

7. OSD KEY INFORMATION

7-1. Key Spec(7KEY)



MENU SELECT UP DOWN RIGHT LEFT POWER LED

7-2. Key Dimensions

7-3. Key Events

KEY	Description
MENU/EXIT	Access to the OSD system, Return to the previous state
SELECT	Choose the Sub Icon or select item
UP	Move the cursor to up, Decrease selected value
DOWN	Move the cursor to down, Increase selected value
LEFT	Move the cursor to up, Decrease selected value
RIGHT	Move the cursor to down, Increase selected value
POWER	Turn off/on the display unit.

7-4. Direct key

KEY	Description	Remark
UP	Changed of Input Source	SOURCE CHANGE
Down	Audio Mute	

7-5. LED Status Color

LED STATUS	OPERATING STATUS	Remark
LED GREEN	NORMAL	
LED AMBER	POWER SAVING	Blinking
LED OFF	POWER OFF	

8. Remote Control



NO	Key Mapping	Function
1	Power	Power on/off
2	Mute	Audio Mute
3	Up	Up
4	Left	Left
5	Right	Right
6	Down	Down
7	Ok	Enter
8	Menu	Main OSD
9	Recall	Exit
10	Source	Input change
11	Green	Volume Down
12	Yellow	Volume Up
13	Blue	Sub Menu
14	FR	FR
15	Pause	Pause
16	FF	play

9. Codec Support

PHOTO (USB)
JPEG(.jpg) / GIF(.gif)
BMP(.bmp) / TIFF (.tif , .tiff)
PNG(.png)
MUSIC (USB)
MP3(.mp3) / ASF(.wma)
AAC (.aac) / Real Format (.ra)
MOVIE (USB)
MPEG2(.mpg , .mpa , .mpe , .mp2 , .vob , .dat) / MJPEG
TS stream(.ts , .mts<AVCHD> , m2ts<BD>
AVI(.avi, .vid, .xvid, .div)
DivX Plus: AVI+MKV
QuickTime: (.mp4, .m4a, .mov)
MKV: (.mkv)
Real Format: (.rm, rv, .rmv, .rmvb)
Microsoft ISO MPEG-4 Video Codec v1(MP4S)

10.Connector Interface

10-1. Interface Position

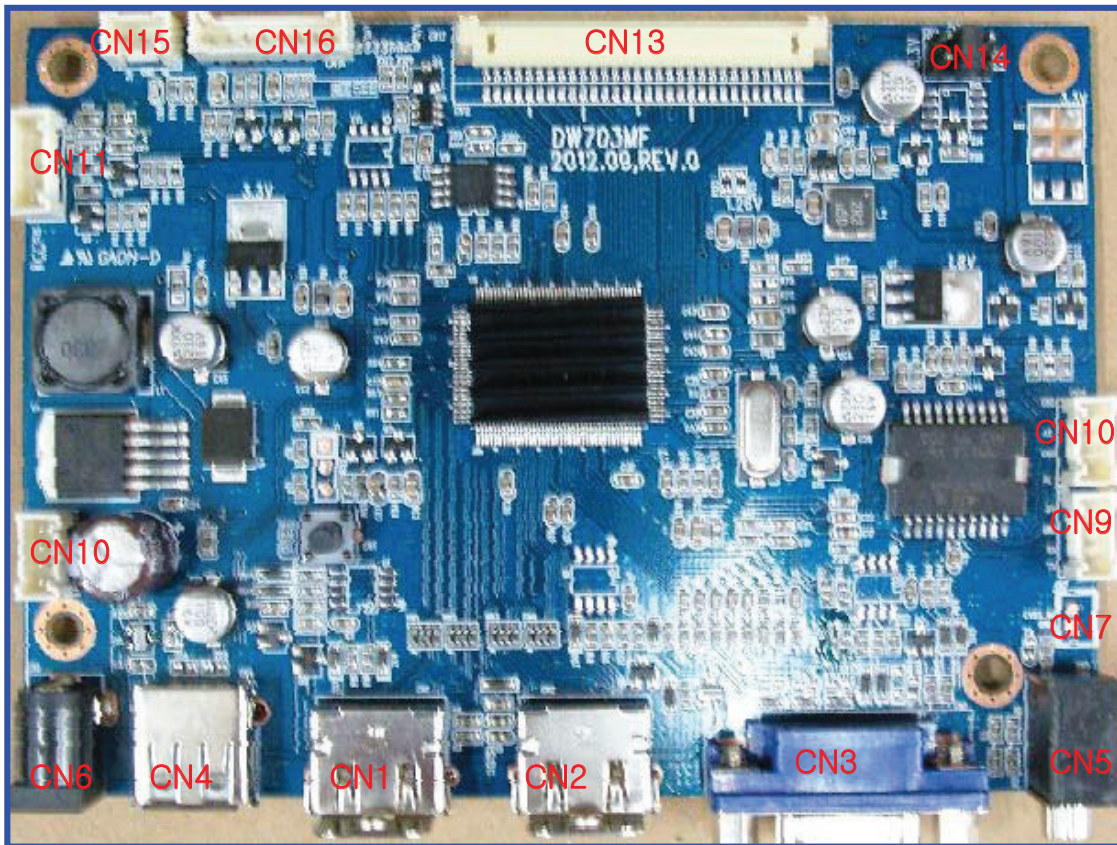

10-2. Interface Information

NO	LOCATION	Option	DESCRIPTION
1	CN6		12V DC IN (DC JACK)
2	CN1 , CN2		HDMI
3	CN3		DSUB 15P(DSH03A-15F-BU)
4	CN4		USB
5	CN7	0	Video IN(SMW200-2P)
6	CN5		AUDIO IN
7	CN11		OSD KEY(SMW200-5P)
8	CN10		AUDIO OUT(SMW200-4P)
9	CN15		IR(SMW200-3P)
10	CN13		LVDS(30PIN)
11	CN9	0	RS232 External control(SMH-200-4P)
12	CN16		INVERTER (SMH-200-8P)
13	CN14		PANEL VCC SELECT (3.3V / 5V / 12V)
14	CN8		12V INPUT (SMW200-04P)

10-2. CN3 : DSUB(RGB)

Pin	Signal	Pin	Signal
1	RED	9	N.C
2	GREEN	10	VGA DETECT
3	BLUE	11	N.C
4	N.C	12	SDA
5	GROUND	13	H-SYNC
6	RED GND	14	V-SYNC
7	GREEN GND	15	SCL
8	BLUE GND		

10-3. CN7 : Video IN(SMW200-02P)

Pin	Signal
1	CVBS IN
2	GND

10-4. CN1,CN2 : HDMI

Pin	Signal	Pin	Signal	Pin	Signal
1	T.M.D.S Data2 shield	9	T.M.D.S Data0-	17	RESERVED
2	T.M.D.S Data2+	10	T.M.D.S Clock Shield	18	+5V
3	T.M.D.S Data2-	11	T.M.D.S Clock+	19	HOT Plug Detect
4	T.M.D.S Data1 shield	12	T.M.D.S Clock-		
5	T.M.D.S Data1+	13	DDC/CEC Ground		
6	T.M.D.S Data1-	14	CEC		
7	T.M.D.S Data0 shield	15	SCL		
8	T.M.D.S Data0+	16	SDA		

10-5. CN13 : LVDS(12507WR-30)

Pin	Signal	Pin	Signal
1	RX00-	16	RXE1+
2	RX00+	17	GND
3	RX01-	18	RXE2-
4	RX01+	19	RXE2+
5	RX02-	20	RXEC-
6	RX02+	21	RXEC-
7	GND	22	RXE3-
8	RXOC-	23	RXE3+
9	RXOC+	24	GND
10	RX03-	25	NC
11	RX03+	26	NC(OPTION)
12	RXE0-	27	NC
13	RXE0+	28	PANEL_VCC
14	GND	29	PANEL_VCC
15	RXE1-	30	PANEL_VCC

10-6. CN12 : 10bit LVDS(12507WR-30) : Optional

10-7. CN16 : INVERTER (SMW200-8P)

Pin	Description
1	SMPS ON/OFF
2	5V
3	12V DC
4	12V DC
5	GND
6	GND
7	DIMMING
8	INVERTER ON/OFF

10-8. CN11 : OSD KEY(SMW200-5P)

Pin	Description
1	KEY1
2	KEY2
3	LED_G
4	LED_R
5	GND

10-9. CN9 : RS232 External control(SMW200-04P)

Pin	Description
1	TXD
2	RXD
3	GND
4	5V_VCC

10-10. CN15 : IR control(SMW200-03P)

Pin	Description
1	IR
2	GND
3	5V_VCC

10-11. CN14 : PANEL VCC SELECT(PIN HEADER 2.54PH)

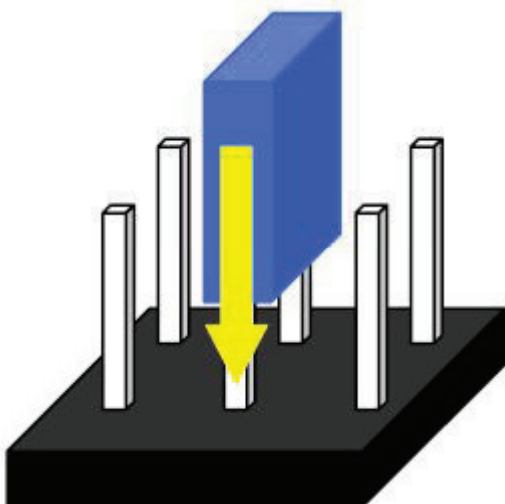

3.3V 5V 12V

CAUTION: Incorrect setting can damage panel

11. Board Dimension

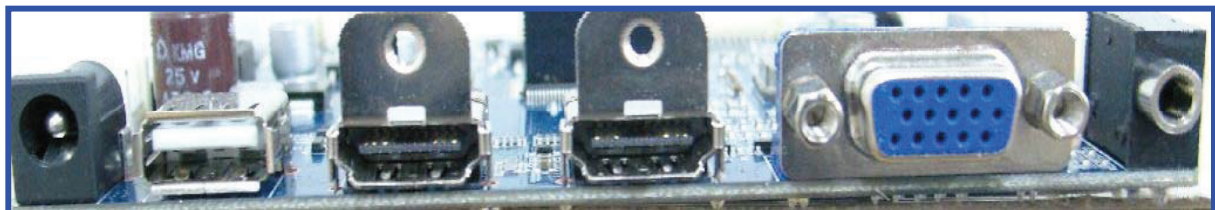
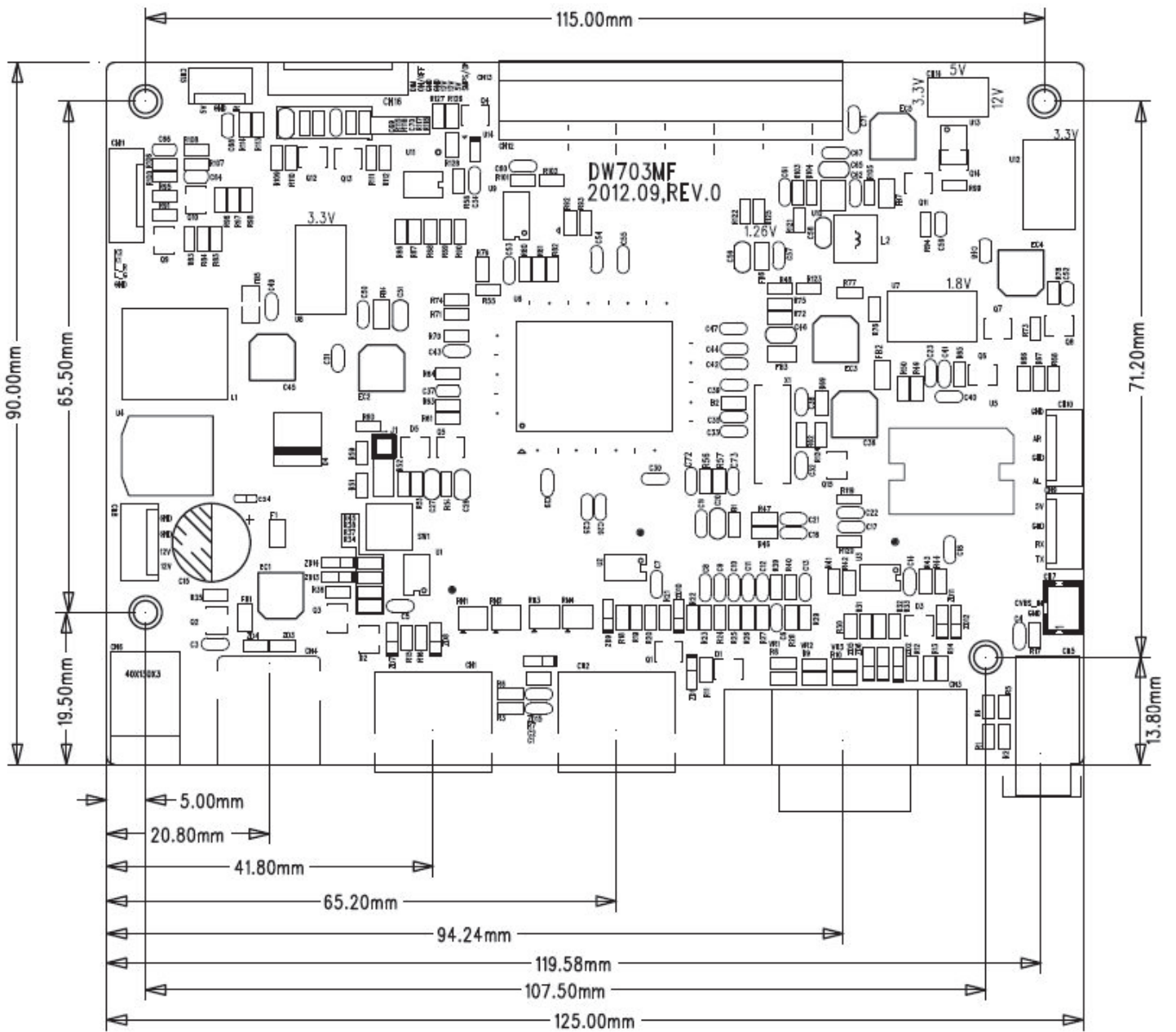

DC IN

USB

2*HDMI

RGB

AUDIO IN